

Mini-Powered Rota-Shafts/1.12" Bore

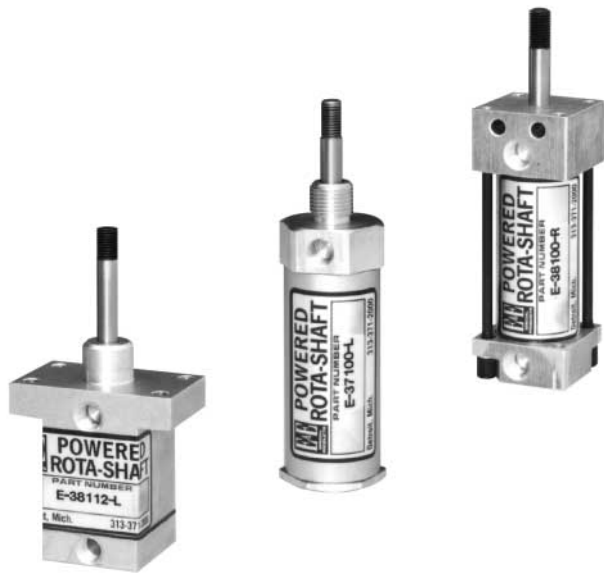

An economical solution to light-duty clamping or material handling applications. Units feature a standard 1 1/8" bore cylinder, 90 right- or left-hand rotation, a range of mounting options with threaded shafts for ease of attaching clamping details.

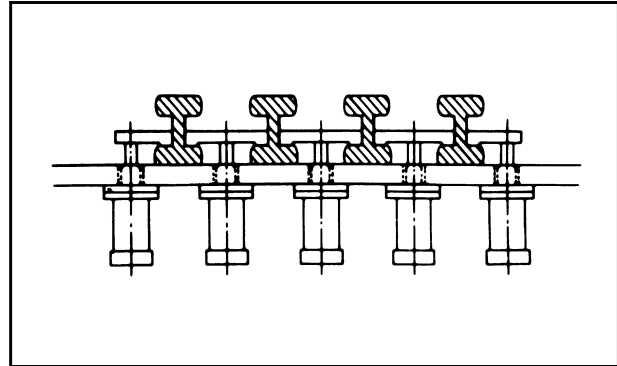

DESIGN FEATURES

- Precision machined cam track
- Hardened and ground housing
- Precision cam follower hardened and ground
- Available in a variety of mounting styles
- Aluminum body
- Stainless steel rod

APPLICATION

Typically used in pull-to-clamp situations where less clamping force is required.

CAD File Name = E38100

Part No. E38100-R, E38100-L

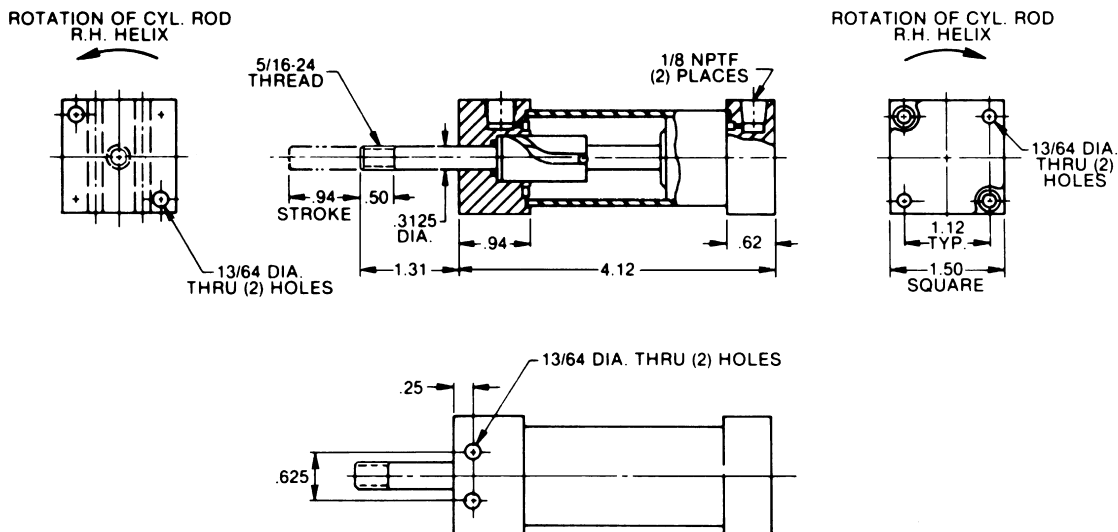

RIGHT HAND SHOWN, LEFT HAND ALSO STANDARD

CAD File Name=E38112
Part No. E38112-R, E38112-L

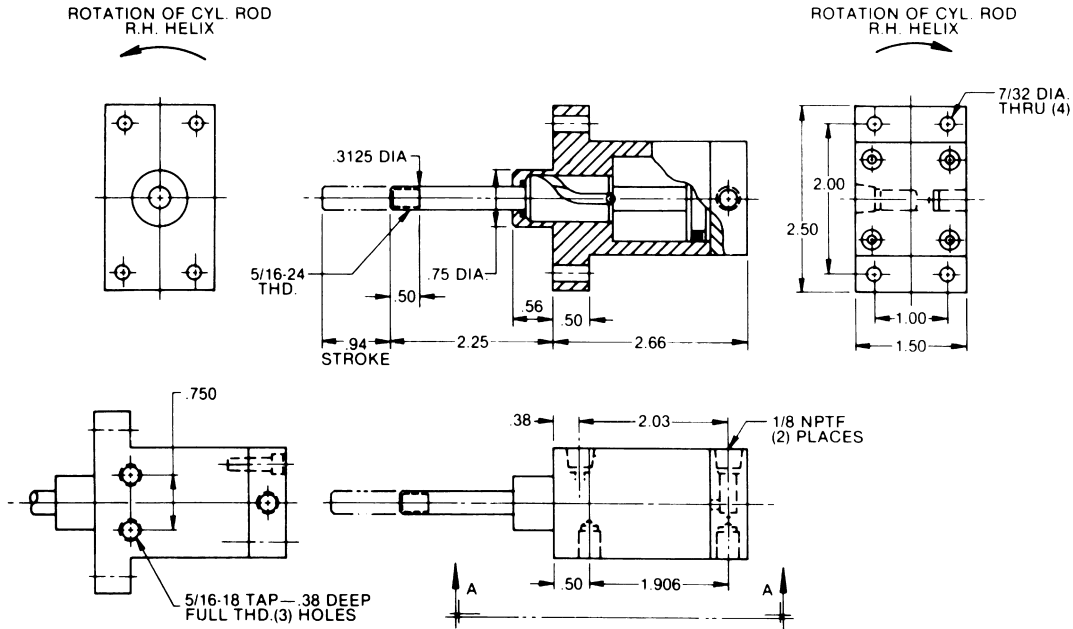

RIGHT HAND SHOWN, LEFT HAND ALSO STANDARD

CAD Directory
 Linear-Rotary/Internal

CAD File Name=E37100
Part No. E37100-R, E37100-L

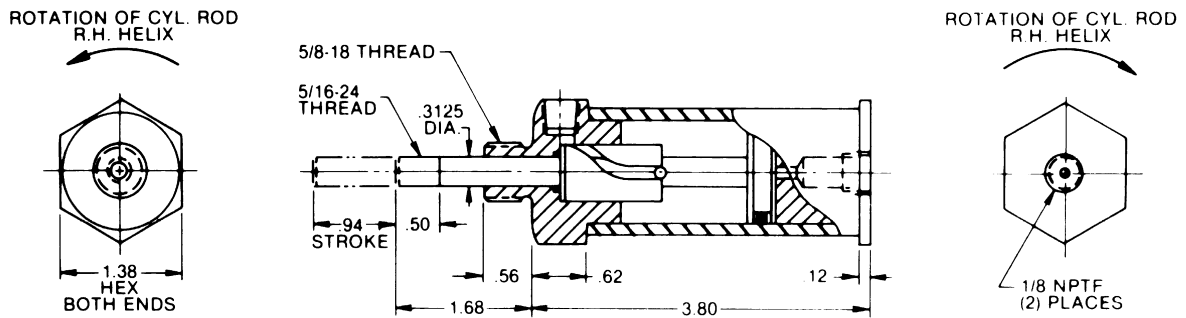

RIGHT HAND SHOWN, LEFT HAND ALSO STANDARD

TRAVEL FOR ALL UNITS SHOWN

- .35 Straight
- .59 During 90°
- .94 Total

CLAMPING FORCE AT MAXIMUM

100 P.S.I. 100 Push 92 Pull

CAD Directory
 Linear-Rotary/Internal

Linear/Rotary Motion