

Rollers – Solid 2" Dia.

Solid rollers have a flat surface and come in sizes from 1-1/2" to 4" in diameter.



ROLL COMPLETE					
CAD FILE NAME	PART NO.	DUROMETER	MATERIAL AVAILABLE		
			(STD)	(W)	(UR)
ERR202RC	ERR-2020-20 ()-C*	20	X	X	
	ERR-2020-35 ()-C*	35	X	X	X
	ERR-2020-60 ()-C*	60	X	X	X
	ERR-2020-80 ()-C*	80	X	X	X
	ERR-2020-95UR-C*	95			X

* Add "P" for precision bearing or add "PC" for sealed precision bearing option.

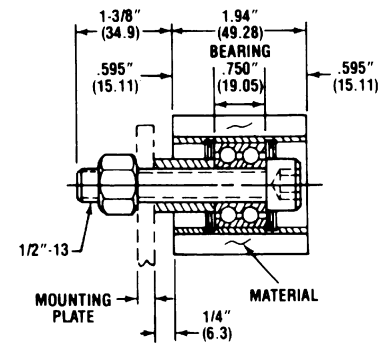
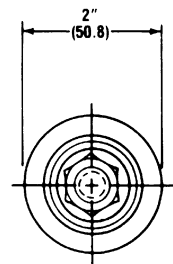

BRAKE ROLL RIGHT/LEFT					
CAD FILE NAME	PART NO.	DUROMETER	MATERIAL AVAILABLE		
			(STD)	(W)	(UR)
EBR202	EBR-2020-20 ()-R/L	20	X	X	
	EBR-2020-35 ()-R/L	35	X	X	X
	EBR-2020-60 ()-R/L	60	X	X	X
	EBR-2020-80 ()-R/L	80	X	X	X
	EBR-2020-95UR-R/L	95			X

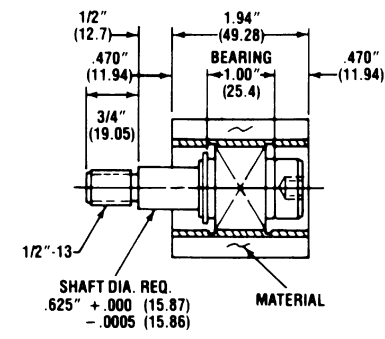
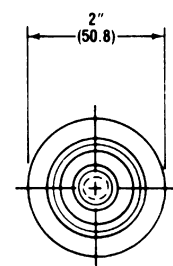

EX10 (FOR 1" SHAFT DRIVE)					
CAD FILE NAME	PART NO.	DUROMETER	MATERIAL AVAILABLE		
			(STD)	(W)	(UR)
ERR202E1	ERR-2020-20 ()-EX10	20	X	X	
	ERR-2020-35 ()-EX10	35	X	X	X
	ERR-2020-60 ()-EX10	60	X	X	X
	ERR-2020-80 ()-EX10	80	X	X	X
	ERR-2020-95UR-EX10	95			X

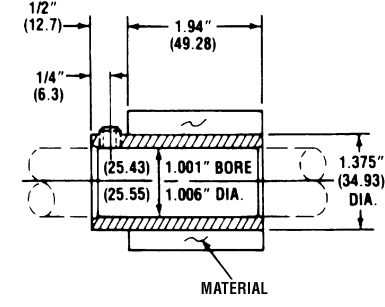
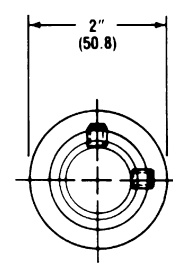

Note: () Is the material to be specified to complete part number. When ordering, indicate your material selection into the part number after the durometer. Indicate nothing for black (STD), "W" for white or "UR" for urethane.

Rollers – Solid 2-1/2" Dia.

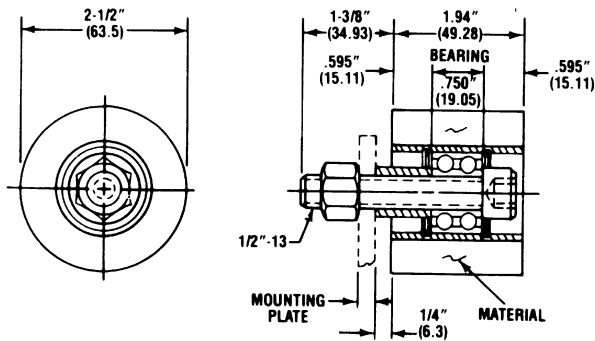

ROLL COMPLETE					
CAD FILE NAME	PART NUMBER	DUROMETER	MATERIAL AVAILABLE		
			(STD)	(W)	(UR)
ERR502C	ERR-502-20 ()-C*	20	X	X	
	ERR-502-35 ()-C*	35	X	X	X
	ERR-502-60 ()-C*	60	X	X	X
	ERR-502-80 ()-C*	80	X	X	X
	ERR-502-95UR-C*	95			X
	ERR-325 ()-C*	20	SPONGE NEOPRENE		

* Add "P" for precision bearing or add "PC" for sealed precision bearing option.

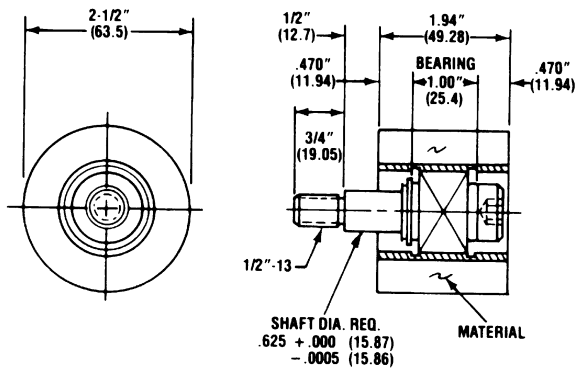

BRAKE ROLL RIGHT/LEFT					
CAD FILE NAME	PART NUMBER	DUROMETER	MATERIAL AVAILABLE		
			(STD)	(W)	(UR)
EBR502	EBR-502-20 ()-R/L	20	X	X	
	EBR-502-35 ()-R/L	35	X	X	X
	EBR-502-60 ()-R/L	60	X	X	X
	EBR-502-80 ()-R/L	80	X	X	X
	EBR-502-95UR-R/L	95			X
	EBR-325 ()-R/L	20	SPONGE NEOPRENE		

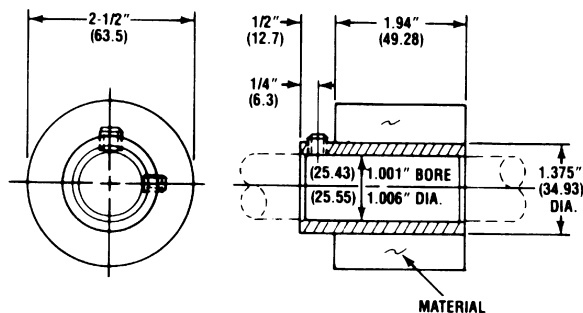

EX10 (FOR 1" SHAFT DRIVE)					
CAD FILE NAME	PART NUMBER	DUROMETER	MATERIAL AVAILABLE		
			(STD)	(W)	(UR)
ERR502E1	ERR-502-20 ()-EX10	20	X	X	
	ERR-502-35 ()-EX10	35	X	X	X
	ERR-502-60 ()-EX10	60	X	X	X
	ERR-502-80 ()-EX10	80	X	X	X
	ERR-502-95UR-EX10	95			X
	ERR-325-EX10	20	SPONGE NEOPRENE		

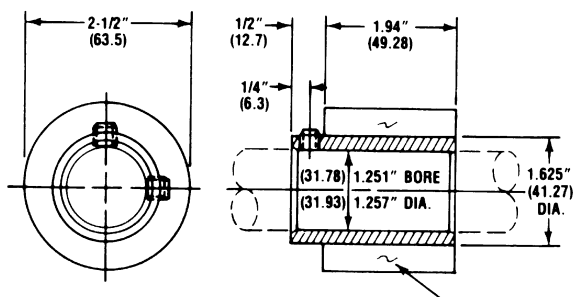

EX12 (FOR 1-1/4" SHAFT DRIVE)					
CAD FILE NAME	PART NUMBER	DUROMETER	MATERIAL AVAILABLE		
			(STD)	(W)	(UR)
ERR502E2	ERR-502-20 ()-EX12	20			
	ERR-502-35 ()-EX12	35			
	ERR-502-60 ()-EX12	60	X		X
	ERR-502-95UR-EX12	95			X
	ERR-502-80 ()-EX12	80			X

Note: () Is the material to be specified to complete part number. When ordering, indicate your material selection into the part number after the durometer. Indicate nothing for black (STD), "W" for white or "UR" for urethane.

Material Handling

Rollers – Solid 4" Dia.

ROLL COMPLETE					
CAD FILE NAME	PART NUMBER	DUROMETER	MATERIAL AVAILABLE		
			(STD)	(W)	(UR)
ERR754C	ERR-754-20 ()-C*	20	X	X	
	ERR-754-35 ()-C*	35	X	X	X
	ERR-754-60 ()-C*	60	X	X	X
	ERR-754-80 ()-C*	80	X	X	X
	ERR-754-95UR-C*	95			X
	ERR-445 ()-C*	20	SPONGE NEOPRENE		

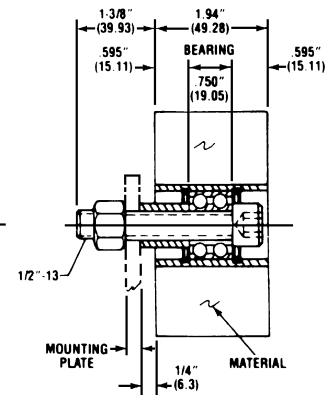
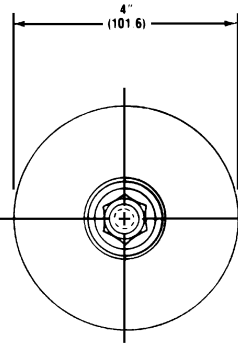

* Add "P" for precision bearing or add "PC" for sealed precision bearing option.

BRAKE ROLL RIGHT/LEFT					
CAD FILE NAME	PART NUMBER	DUROMETER	MATERIAL AVAILABLE		
			(STD)	(W)	(UR)
EBR754	EBR-754-20 ()-R/L	20	X	X	
	EBR-754-35 ()-R/L	35	X	X	X
	EBR-754-60 ()-R/L	60	X	X	X
	EBR-754-80 ()-R/L	80	X	X	X
	EBR-754-95UR-R/L	95			X
	EBR-445 ()-R/L	20	SPONGE NEOPRENE		

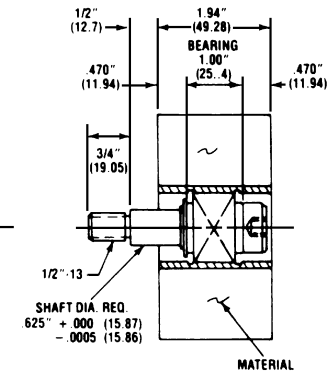
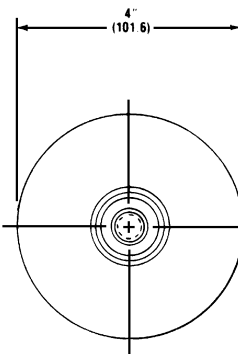

EX10 (FOR 1" SHAFT DRIVE)					
CAD FILE NAME	PART NUMBER	DUROMETER	MATERIAL AVAILABLE		
			(STD)	(W)	(UR)
ERR754E1	ERR-754-20 ()-EX10	20	X	X	
	ERR-754-35 ()-EX10	35	X	X	X
	ERR-754-60 ()-EX10	60	X	X	X
	ERR-754-80 ()-EX10	80	X	X	X
	ERR-754-95UR-EX10	95			X
	ERR-445 ()-EX10	20	SPONGE NEOPRENE		

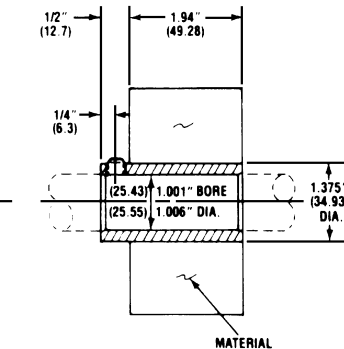
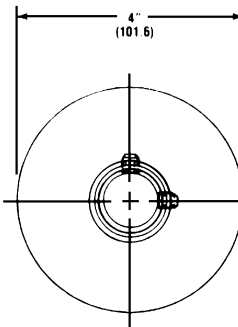

EX12 (FOR 1-1/4" SHAFT DRIVE)					
CAD FILE NAME	PART NUMBER	DUROMETER	MATERIAL AVAILABLE		
			(STD)	(W)	(UR)
ERR754E2	ERR-754-20 ()-EX12	20			
	ERR-754-35 ()-EX12	35	X		
	ERR-754-60 ()-EX12	60	X	X	X
	ERR-754-80 ()-EX12	80			X
	ERR-754-95UR-EX12	95			X

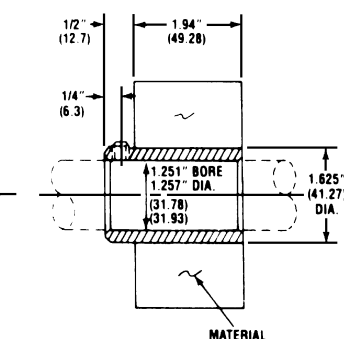
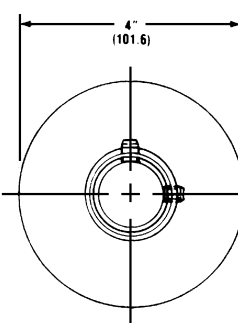

Note: () Is the material to be specified to complete part number. When ordering, indicate your material selection into the part number after the durometer. Indicate nothing for black (STD), "W" for white or "UR" for urethane.