

Adjusting Screws

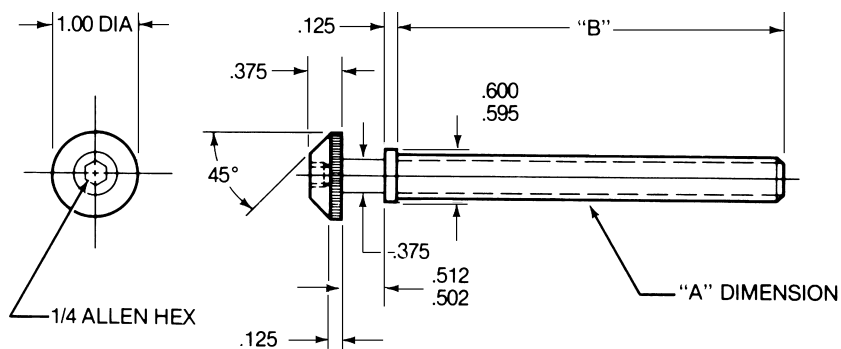

HEAT TREAT AND FINISH TO BE EQUIVALENT TO SAE GRADE 8 STANDARDS.

CAD FILE NAME	PART NUMBER	A	B THD. LENGTH
E3820SC	E3820-1.00	3/8 - 20	1.00
	E3820-2.00	3/8 - 20	2.00
	E3820-3.00	3/8 - 20	3.00
	E3820-4.00	3/8 - 20	4.00
	E3820-5.00	3/8 - 20	5.00
	E3820-6.00	3/8 - 20	6.00
	E3820-7.00	3/8 - 20	7.00
	E3820-8.00	3/8 - 20	8.00
	E3820-9.00	3/8 - 20	9.00
	E3820-10.00	3/8 - 20	10.00
	E3820-11.00	3/8 - 20	11.00
	E3820-12.00	3/8 - 20	12.00

CAD FILE NAME	PART NUMBER	A	B THD. LENGTH
E1220SC	E1220-1.00	1/2 - 20	1.00
	E1220-2.00	1/2 - 20	2.00
	E1220-3.00	1/2 - 20	3.00
	E1220-4.00	1/2 - 20	4.00
	E1220-5.00	1/2 - 20	5.00
	E1220-6.00	1/2 - 20	6.00
	E1220-7.00	1/2 - 20	7.00
	E1220-8.00	1/2 - 20	8.00
	E1220-9.00	1/2 - 20	9.00
	E1220-10.00	1/2 - 20	10.00
	E1220-11.00	1/2 - 20	11.00
	E1220-12.00	1/2 - 20	12.00

“Stretch”

The shortest standard component is given. You may “Stretch” the unit to the desired length.