



E&E SPECIAL PRODUCTS
7200 MILLER DRIVE
WARREN, MI 48092
586-978-3377 / 586-978-3378 FAX

Tapered "L-Pins"

CAD File Name E-2545-4
Part No. E-2545-4

CAD File Name E-2545-5
Part No. E-2545-5

CAD File Name E-2545-6
Part No. E-2545-6

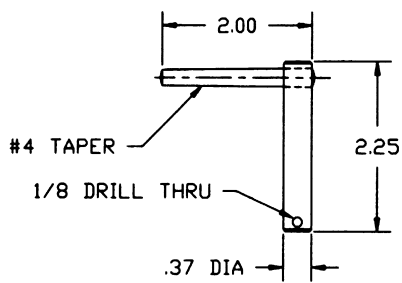

Taper 4

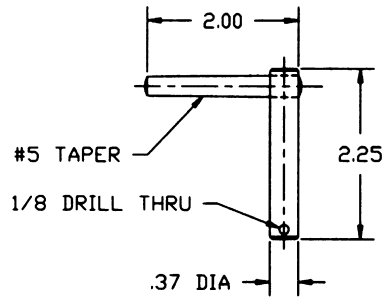

Taper 5

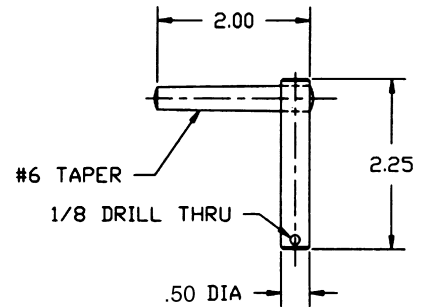

Taper 6

Typical Application

