

Grippers "EHS" High Speed Tool Steel

EHS-SQUARE-"C"-BORE DESIGN-STRAIGHT SERRATIONS							
CAD FILE NAME	PART NUMBER	A DIA.	B	C	D	TOOTH	PATTERN
EHS92CSS	EHS-92-C-SS*	1/2	3/8	1/4	#10 SHCS	FINE/EX-FINE/SUPER-FINE	
	EHS-95-C-SS*	1/2	1/2	1/4	#10 SHCS	FINE/EX-FINE/SUPER-FINE	
EHS963CSS	EHS-962-C-SS*	5/8	3/8	1/4	#10 SHCS	FINE/EX-FINE	
	EHS-9625-C-SS*	5/8	1/2	1/4	#10 SHCS	FINE/EX-FINE	
	EHS-963-C-SS	5/8	3/8	1/4	#10 SHCS	COARSE	
EHS98CSS	EHS-9635-C-SS	5/8	1/2	1/4	#10 SHCS	COARSE	
	EHS-97-C-SS*	3/4	1/2	5/16	1/4 SHCS	FINE/EX-FINE	
EHS102CSS	EHS-98-C-SS	3/4	1/2	5/16	1/4 SHCS	COARSE	
	EHS-101-C-SS*	1	1/2	5/16	1/4 SHCS	FINE/EX-FINE	
	EHS-102-C-SS	1	1/2	5/16	1/4 SHCS	COARSE	

* Optional tooth patterns are available, specify "SF" for Super-Fine, "EF" for Extra-Fine to the end of the part number.

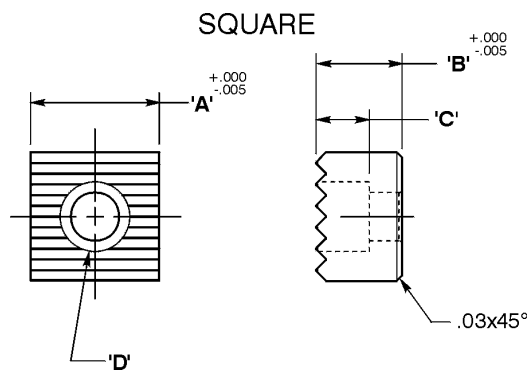

EHS-ADJUSTABLE					
CAD FILE NAME	PART NUMBER	A	B	INT HEX	TOOTH PATTERN
EHS0230	EHS-0230	1/2	3/8-24	1/8	EX-FINE
	EHS-0231	1	3/8-24	1/8	EX-FINE
	EHS-0235	1 1/2	3/8-24	1/8	EX-FINE
	EHS-0370	1/2	3/8-16	1/8	EX-FINE
	EHS-0371	1	3/8-16	1/8	EX-FINE
EHS0240	EHS-0375	1 1/2	3/8-16	1/8	EX-FINE
	EHS-0240	1	1/2-20	3/16	FINE
	EHS-0500	1 1/2	1/2-20	3/16	FINE
	EHS-0510	1	1/2-13	3/16	FINE
EHS06201	EHS-0515	1 1/2	1/2-13	3/16	FINE
	EHS-0620x1	1	5/8-18	1/4	FINE
	EHS-0620	1 1/2	5/8-18	1/4	FINE
	EHS-0625x1	1	5/8-11	1/4	FINE
EHS07501	EHS-0625	1 1/2	5/8-11	1/4	FINE
	EHS-0750x1	1	3/4-16	5/16	FINE
	EHS-0750	1 1/2	3/4-16	5/16	FINE
	EHS-0755x1	1	3/4-10	5/16	FINE
	EHS-0755	1 1/2	3/4-10	5/16	FINE

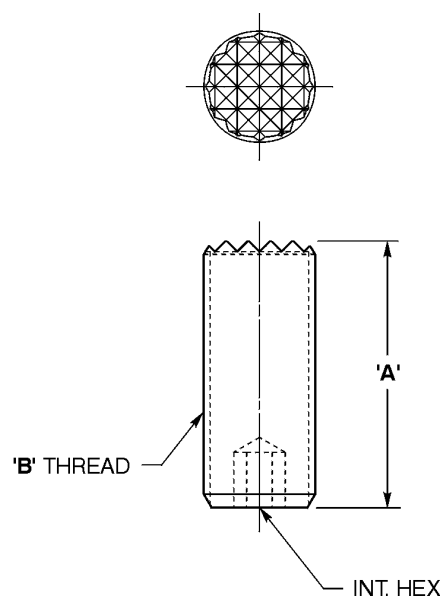

EHS-ANGLE GRIP							
CAD FILE NAME	PART NUMBER	A	B	C	D	E	TOOTH PATTERN
EHS110	EHS-110	9/16	3/8	#10-32	.65	.60	SMOOTH
EHS1274	EHS-127-4	9/16	3/8	#10-32	.65	.60	4-POINT Hex
EHS12712	EHS-127-12	9/16	3/8	#10-32	.65	.60	FINE
EHS1284	EHS-128-4	3/4	1/2	1/4-28	.88	.81	4-POINT
EHS12822	EHS-128-22	3/4	1/2	1/4-28	.88	.81	FINE
EHS1583	EHS-158-3	3/4	1/2	1/4-28	.88	.81	3 POINT/90 STRAIGHT
EHS1304	EHS-130-4	9/16	3/8	#10-32	.65	.60	STRAIGHT
EHS1455	EHS-145-5	9/16	3/8	#10-32	.65	.60	ANGULAR
EHS1503	EHS-150-3	9/16	3/8	#10-32	.65	.60	3 POINT/90 STRAIGHT
EHS11010MM	EHS-110-10MM	.394	3/8	#10-32	.65	.60	SMOOTH
EHS127410MM	EHS-127-4-10MM	.394	3/8	#10-32	.65	.60	4-POINT
EHS130410MM	EHS-130-4-10MM	.394	3/8	#10-32	.65	.60	STRAIGHT
EHS145510MM	EHS-145-5-10MM	.394	3/8	#10-32	.65	.60	ANGULAR

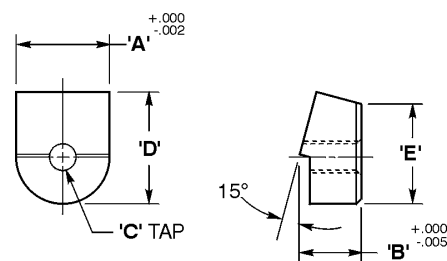

EHS-110 SHOWN

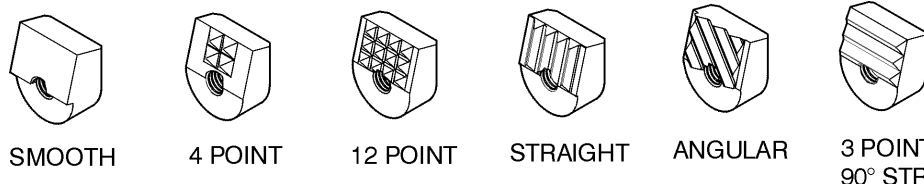

CAD Directory

Mach-Tool\Grippers

Note: The shortest standard components is given, you may "stretch" the unit to the desired length.