

Swivots-Hex Head Adjustable

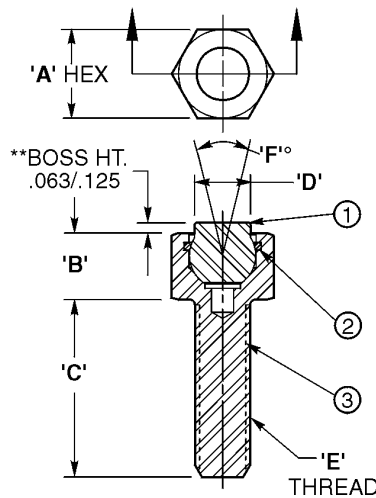

E&E SPECIAL PRODUCTS
 7200 MILLER DRIVE
 WARREN, MI 48092
E&ESP 586-978-3377 / 586-978-3378 FAX



REPLACEABLE BALL STYLE HEX HEAD DESIGN														
ASSEMBLIES								COMPONENTS						
CAD FILE NAME	PART NUMBER	A HEX	B HEAD	C THD LENGTH	D BOSS DIA	E THD	F DEGREE SWIVEL	BALL DIA	1 BALL	2 O-RING	3 HOUSING	AVAIL. TOOTH PATTERN	LOAD RATING	
EBUH0124F or EUBUH0124S	EBUH-0124-(*)-**	3/8	1/4	1/2	5/32	#10-24	28°	3/16	EBUB-100-(*)-**	EBUR-100	EBUH-0124-H	SF	1176	
	EBUH-0124x1-(*)-**	3/8	1/4	1	5/32	#10-24	28°	3/16	EBUB-100-(*)-**	EBUR-100	EBUH-0124-1-H	SF	1176	
	EBUH-0132-(*)-**	3/8	1/4	1/2	5/32	#10-32	28°	3/16	EBUB-100-(*)-**	EBUR-100	EBUH-0132-H	SF	1176	
	EBUH-0132x1-(*)-**	3/8	1/4	1	5/32	#10-32	28°	3/16	EBUB-100-(*)-**	EBUR-100	EBUH-0132-1-H	SF	1176	
EBUH01250F or EUBUH0250S	EBUH-0250-(*)-**	7/16	5/16	1/2	1/4	1/4-20	24°	9/32	EBUB-200-(*)-**	EBUR-200	EBUH-0250-H	EF/SF	2441	
	EBUH-0251-(*)-**	7/16	5/16	1	1/4	1/4-20	24°	9/32	EBUB-200-(*)-**	EBUR-200	EBUH-0251-H	EF/SF	2441	
	EBUH-0251x1½-(*)-**	7/16	5/16	1 1/2	1/4	1/4-20	24°	9/32	EBUB-200-(*)-**	EBUR-200	EBUH-0251-1 ½-H	EF/SF	2441	
	EBUH-0280-(*)-**	7/16	5/16	1/2	1/4	1/4-28	24°	9/32	EBUB-200-(*)-**	EBUR-200	EBUH-0280-H	EF/SF	2441	
	EBUH-0281-(*)-**	7/16	5/16	1	1/4	1/4-28	24°	9/32	EBUB-200-(*)-**	EBUR-200	EBUH-0281-H	EF/SF	2441	
	EBUH-0281x1½-(*)-**	7/16	5/16	1 1/2	1/4	1/4-28	24°	9/32	EBUB-200-(*)-**	EBUR-300	EBUH-0281-1 ½-H	EF/SF	2441	
EBUH0313F or EUBUH0310S	EBUH-0310-(*)-**	1/2	3/8	1/2	5/16	5/16-18	32°	3/8	EBUB-300-(*)-**	EBUR-300	EBUH-0310-H	EF/SF	2792	
	EBUH-0312-(*)-**	1/2	3/8	1	5/16	5/16-18	32°	3/8	EBUB-300-(*)-**	EBUR-300	EBUH-0312-H	EF/SF	2792	
	EBUH-0312x1½-(*)-**	1/2	3/8	1 1/2	5/16	5/16-18	32°	3/8	EBUB-300-(*)-**	EBUR-300	EBUH-0312-1 ½-H	EF/SF	2792	
	EBUH-0320-(*)-**	1/2	3/8	1/2	5/16	5/16-24	32°	3/8	EBUB-300-(*)-**	EBUR-300	EBUH-0320-H	EF/SF	2792	
	EBUH-0321-(*)-**	1/2	3/8	1	5/16	5/16-24	32°	3/8	EBUB-300-(*)-**	EBUR-300	EBUH0321-H	EF/SF	2792	
	EBUH-0321x1½-(*)-**	1/2	3/8	1 1/2	5/16	5/16-24	32°	3/8	EBUB-300-(*)-**	EBUR-300	EBUH-0321-1 ½-H	EF/SF	2792	
EBUH0230F or EUBUH0230S	EBUH-0230-(*)-**	5/8	1/2	1/2	3/8	3/8-24	22°	1/2	EBUB-500-(*)-**	EBUR-500	EBUH-0230-H	EF/SF	3446	
	EBUH-0231-(*)-**	5/8	1/2	1	3/8	3/8-24	22°	1/2	EBUB-500-(*)-**	EBUR-500	EBUH-0231-H	EF/SF	3446	
	EBUH-0231x1½-(*)-**	5/8	1/2	1 1/2	3/8	3/8-24	22°	1/2	EBUB-500-(*)-**	EBUR-500	EBUH-0231-1 ½-H	EF/SF	3446	
	EBUH-0370-(*)-**	5/8	1/2	1/2	3/8	3/8-16	22°	1/2	EBUB-500-(*)-**	EBUR-500	EBUH-0370-H	EF/SF	3446	
	EBUH-0375-(*)-**	5/8	1/2	1	3/8	3/8-16	22°	1/2	EBUB-500-(*)-**	EBUR-500	EBUH-0375-H	EF/SF	3446	
	EBUH-0375x1½-(*)-**	5/8	1/2	1 1/2	3/8	3/8-16	22°	1/2	EBUB-500-(*)-**	EBUR-500	EBUH-0375-1 ½-H	EF/SF	3446	

*MUST SPECIFY STYLE OR BALL BY INDICATING "S" FOR SERRATED, "SF" FOR SUPER FINE SERRATIONS, "F" FOR FLAT OR "D" FOR DELRIN AND OPTION IF REQUIRED.

**SPECIFY "T" FOR "TALL" HEIGHT OPTION. LEAVE BLANK FOR STANDARD HEIGHT.

CAD Directory

Mach-Tool\Grippers

Note: The shortest standard components is given, you may "stretch" the unit to the desired length.