

Actuator Parts

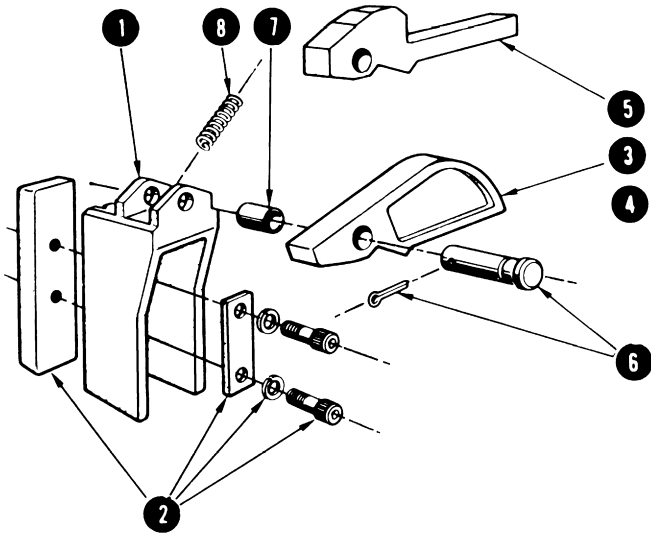

E&E SPECIAL PRODUCTS
 7200 MILLER DRIVE
 WARREN, MI 48092
 586-978-3377 / 586-978-3378 FAX



ITEM	PART NUMBER	DESCRIPTION
1	A5	BODY CASTING
2	A6	MOUNTING PLATE ASSEMBLY
3	50/51	15° ARM
4	59/60	30° ARM
5	53/54	SPECIAL ARM
6	A7	HEAVY DUTY HARDENED PIN ASSEMBLY
7	P-50-6	BUSHING
8	9-0808-11 (REG. 6#)	SPRING-FOR MODELS A-50, A-51, A-53 AND A-54
	9-0808-21 (H.D. 16#)	

Typical Application

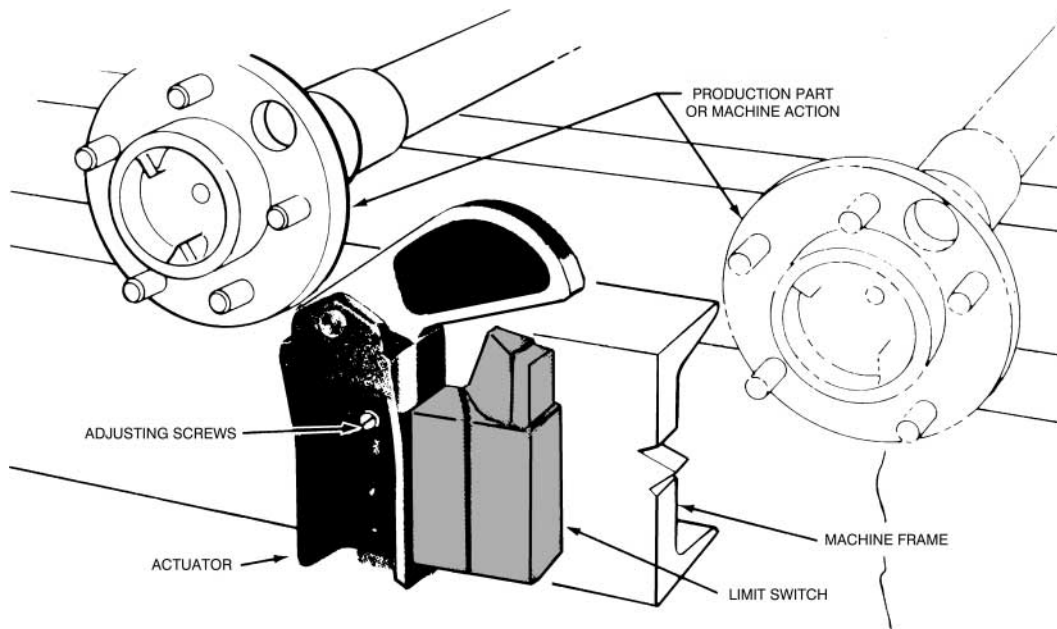

Limit Switch Actuators

CAD File Name A-50, A-51

Part No. A50 R.H. (shown), A51 L.H.

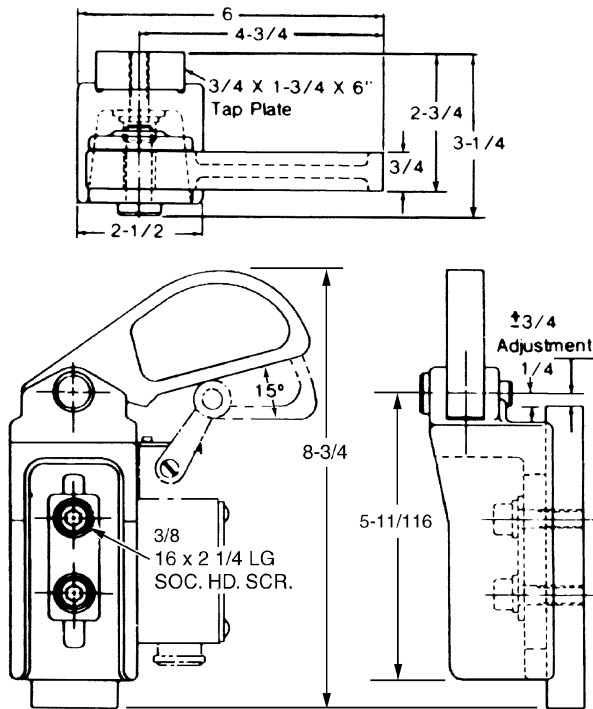

CAD File Name A-53, A-54

Part No. A53 R.H. (shown), A54 L.H.

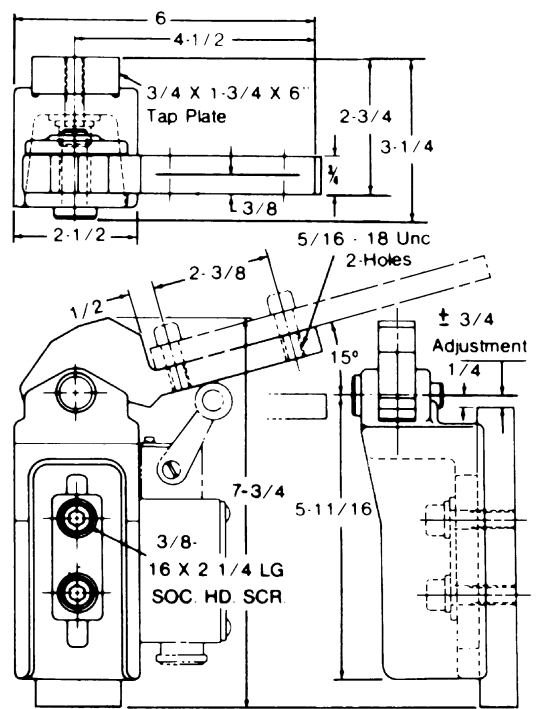

These actuators are stocked less mounting holes.

They accommodate most of the popular standard and plug-in machine tool or heavy duty limit switches.

SPECIAL ORDERS FOR LIMIT SWITCH MOUNTING HOLES

When ordering limit switch with mounting holes in actuator, the following descriptive limit switch information is required:

Make (Trade Name) Allen-Bradley
 Model or Type 802T-A1P
 Series C

Heat Treated Arms up to (Rc 56-58) Available.

CAD File Name A-59, A-60

Part No. A59 R.H. (shown), A60 L.H.

