

E&E Micro Adjustment Dials

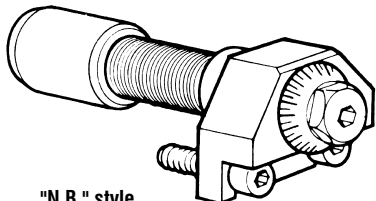

"N.B." style mounting

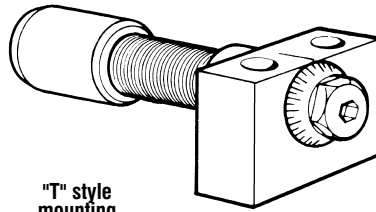

"T" style mounting

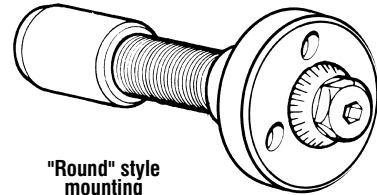

"Round" style mounting

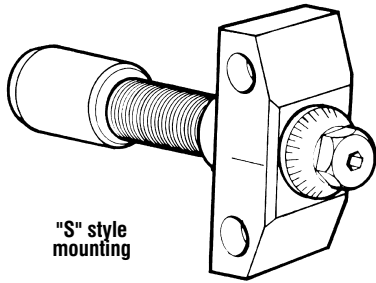

"S" style mounting

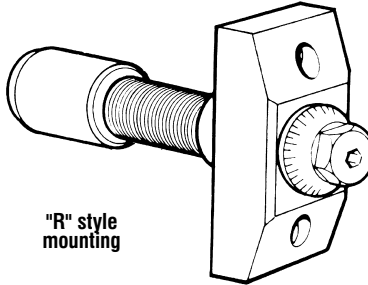

"R" style mounting

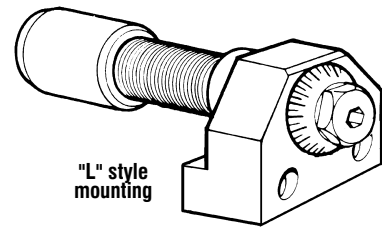

"L" style mounting

E&E Micro Adjustment Dials

E&E Special Products offers a series of Micro Adjustment Dials for precision adjustment of cutting tools, boring bars, tool blocks, V-blocks, end stops and other machine components. A calibrated dial mounted on the tool block is graduated in .0005 increments. Rotating the dial advances or retracts a precision screw that positions the tool with micrometer accuracy. Hand setting is eliminated.

ORDERING INFORMATION

Select Mounting Style and Thread Dimensions

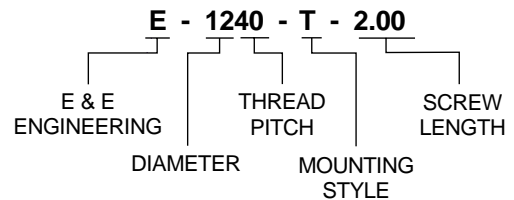

Micro Adjustment Dial Features:

- Reference calibrations permit quick, accurate adjustment of tools or stops to within tenths setting.
- Backlash is minimized due to fine pitch micrometer threaded screw fitted to precision bushings.
- Available in 6 mounting styles adaptable to virtually any tooling.
- Eliminates the need for costly, quick-change, pre-set tooling.
- Two micrometer thread sizes available: 3/8-40 and 1/2-40.

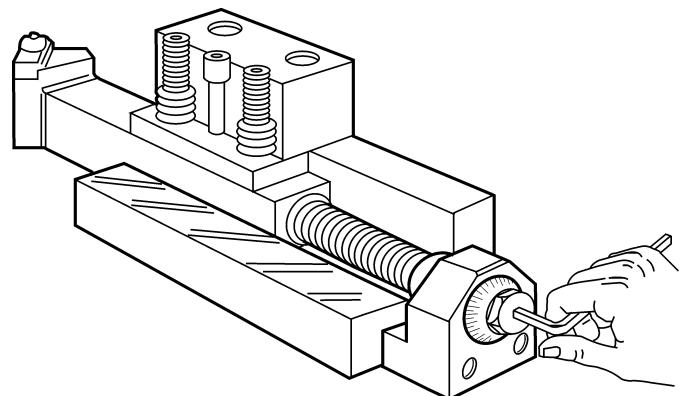
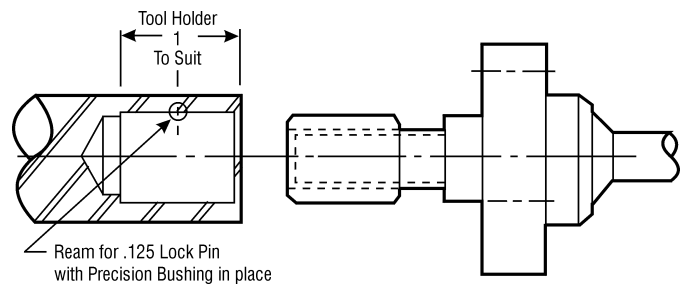

Micro Adjustment Dial

“R” Mount

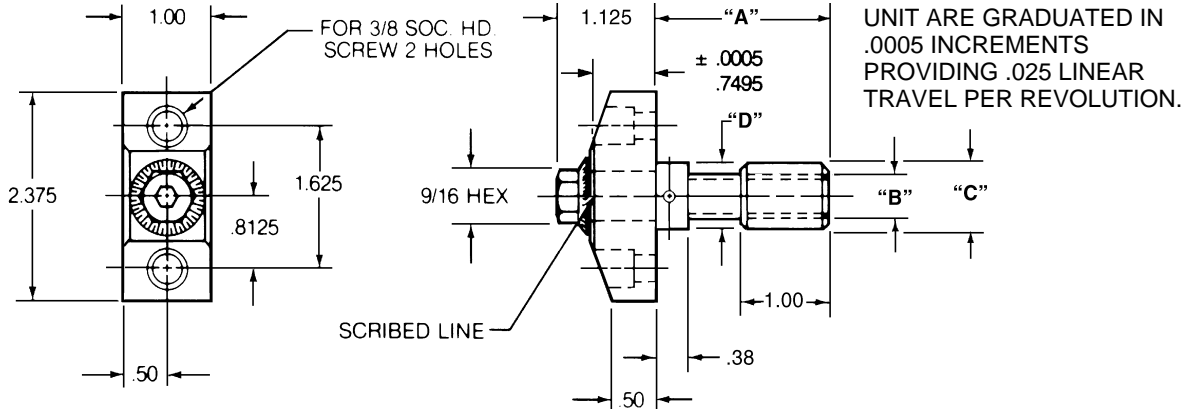

CAD FILE NAME	PART NUMBER	A	B	C	D
E1240R2	E1240-R-2.00	2.00	1/2 - 40 L.H.	.7495	.734
	E1240-R-3.00	3.00	1/2 - 40 L.H.	.7495	.734
	E1240-R-4.72	4.72	1/2 - 40 L.H.	.7495	.734
E3840R2	E3840-R-2.00	2.00	3/8 - 40 L.H.	.6245	.609
	E3840-R-3.00	3.00	3/8 - 40 L.H.	.6245	.609
	E3840-R-4.72	4.72	3/8 - 40 L.H.	.6245	.609

“S” Mount

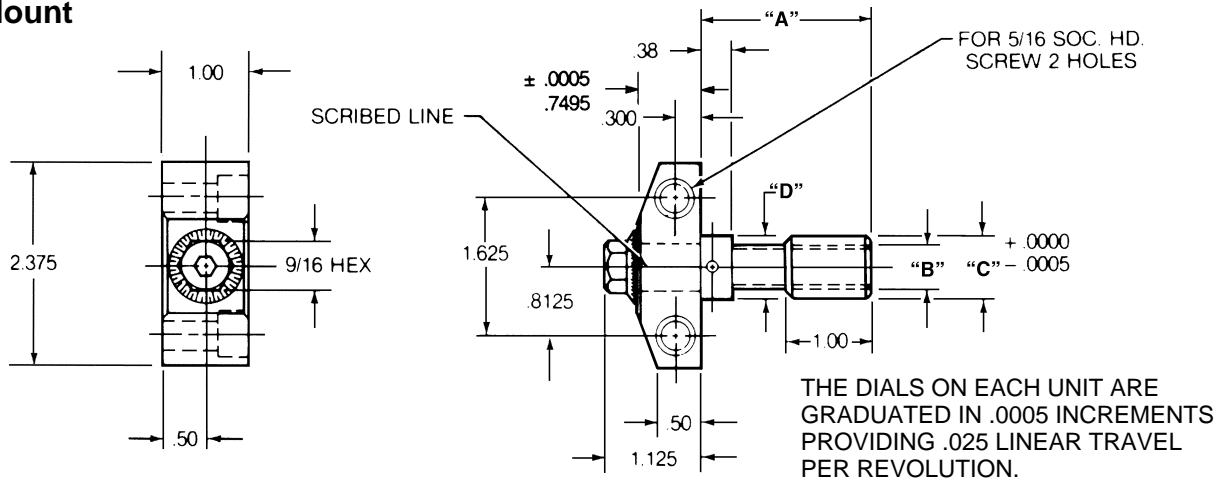

CAD FILE NAME	PART NUMBER	A	B	C	D
E1240S2	E1240-S-2.00	2.00	1/2 - 40 L.H.	.7495	.734
	E1240-S-3.00	3.00	1/2 - 40 L.H.	.7495	.734
	E1240-S-4.72	4.72	1/2 - 40 L.H.	.7495	.734
E3840S2	E3840-S-2.00	2.00	3/8 - 40 L.H.	.6245	.609
	E3840-S-3.00	3.00	3/8 - 40 L.H.	.6245	.609
	E3840-S-4.72	4.72	3/8 - 40 L.H.	.6245	.609

Micro Adjustment Dial

“N.B.” Mount

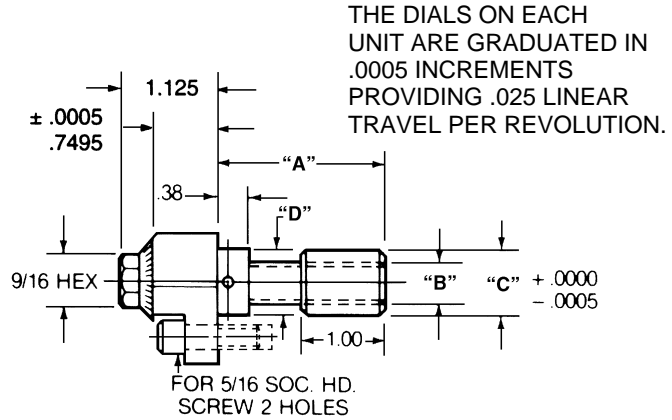
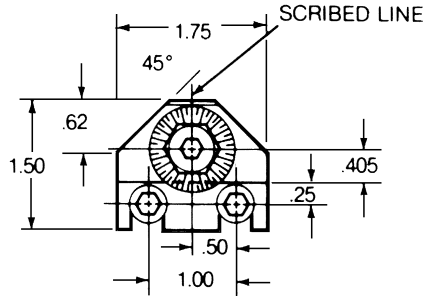

CAD FILE NAME	PART NUMBER	A	B	C	D
E1240N2	E1240-NB-2.00	2.00	1/2 - 40 L.H.	.7495	.734
	E1240-NB-3.00	3.00	1/2 - 40 L.H.	.7495	.734
	E1240-NB-4.72	4.72	1/2 - 40 L.H.	.7495	.734
E3840N2	E3840-NB-2.00	2.00	3/8 - 40 L.H.	.6245	.609
	E3840-NB-3.00	3.00	3/8 - 40 L.H.	.6245	.609
	E3840-NB-4.72	4.72	3/8 - 40 L.H.	.6245	.609

“T” Mount

THE DIALS ON EACH UNIT ARE GRADUATED IN .0005 INCREMENTS PROVIDING .025 LINEAR TRAVEL PER REVOLUTION.

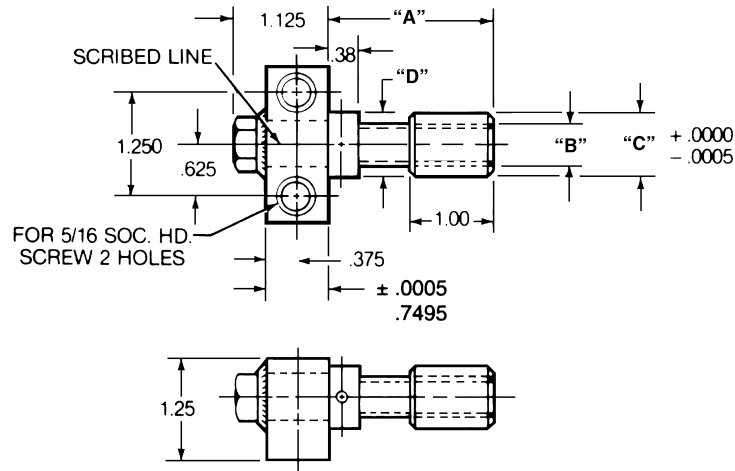
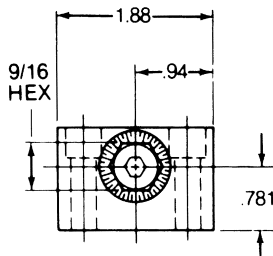

CAD FILE NAME	PART NUMBER	A	B	C	D
E1240T2	E1240-T-2.00	2.00	1/2 - 40 L.H.	.7495	.734
	E1240-T-3.00	3.00	1/2 - 40 L.H.	.7495	.734
	E1240-T-4.72	4.72	1/2 - 40 L.H.	.7495	.734
E3840T2	E3840-T-2.00	2.00	3/8 - 40 L.H.	.6245	.609
	E3840-T-3.00	3.00	3/8 - 40 L.H.	.6245	.609
	E3840-T-4.72	4.72	3/8 - 40 L.H.	.6245	.609

“Stretch”

The shortest standard component is given. You may “Stretch” the unit to the desired length.

Micro Adjustment Dial

Round Mount

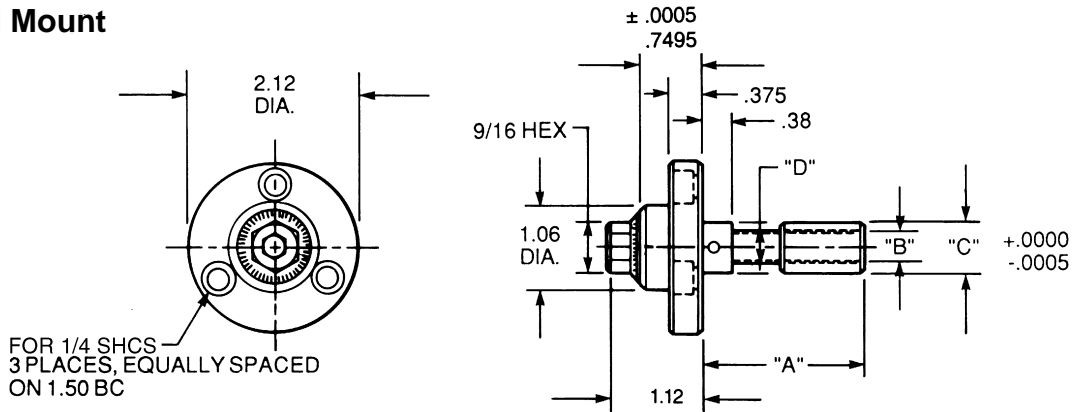

CAD FILE NAME	PART NUMBER	A	B	C	D
E1240RD2	E1240-RD-2.00	2.00	1/2 - 40 L.H.	.7495	.734
	E1240-RD-3.00	3.00	1/2 - 40 L.H.	.7495	.734
	E1240-RD-4.72	4.72	1/2 - 40 L.H.	.7495	.734
E3840RD2	E3840-RD-2.00	2.00	3/8 - 40 L.H.	.6245	.609
	E3840-RD-3.00	3.00	3/8 - 40 L.H.	.6245	.609
	E3840-RD-4.72	4.72	3/8 - 40 L.H.	.6245	.609

"L" Mount

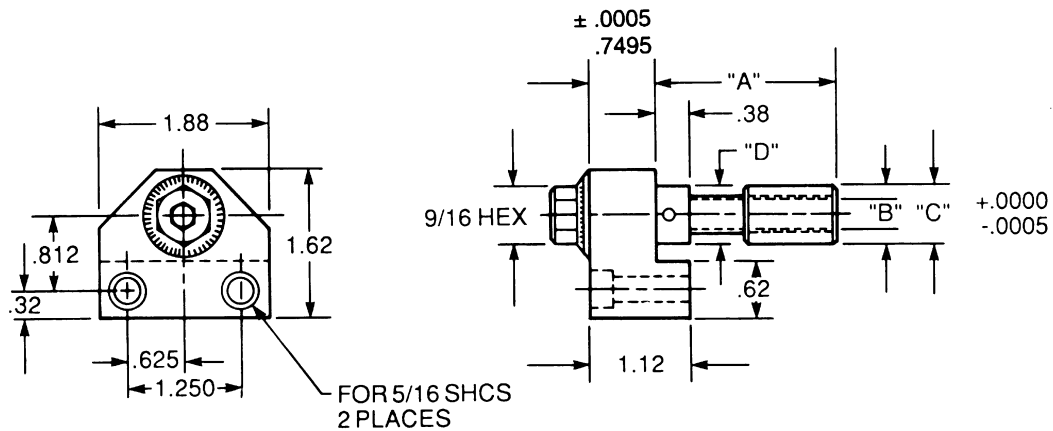

CAD FILE NAME	PART NUMBER	A	B	C	D
E1240L2	E1240-L-2.00	2.00	1/2 - 40 L.H.	.7495	.734
	E1240-L-3.00	3.00	1/2 - 40 L.H.	.7495	.734
	E1240-L-4.72	4.72	1/2 - 40 L.H.	.7495	.734
E3840L2	E3840-L-2.00	2.00	3/8 - 40 L.H.	.6245	.609
	E3840-L-3.00	3.00	3/8 - 40 L.H.	.6245	.609
	E3840-L-4.72	4.72	3/8 - 40 L.H.	.6245	.609