

Metric Self-Aligning Couplers



Features:

- ❑ Eliminates expensive precision machining for mounting fixed or rigid guide in cylinder for slide applications.
- ❑ Increases cylinder efficiency by eliminating friction causes by misalignment.
- ❑ Compensates for 2° angular error and x 1.6 lateral misalignment on push and pull stroke.
- ❑ Greater Reliability-Reduces cylinder and component wear.
- ❑ Simplifies alignment problems in the field.



SELF-ALIGNING

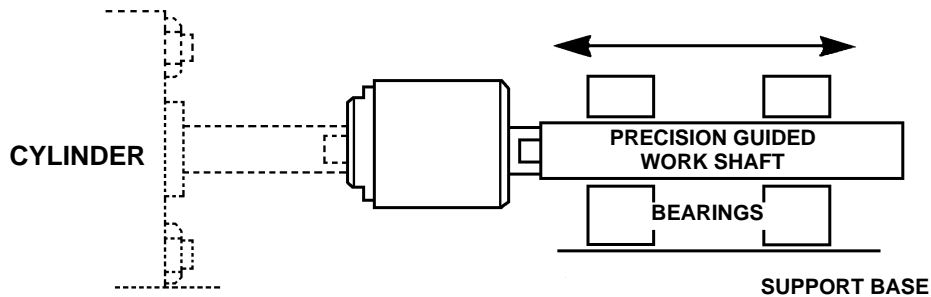

(VIEWS EXAGGERATED TO SHOW ALIGNMENT FEATURES)

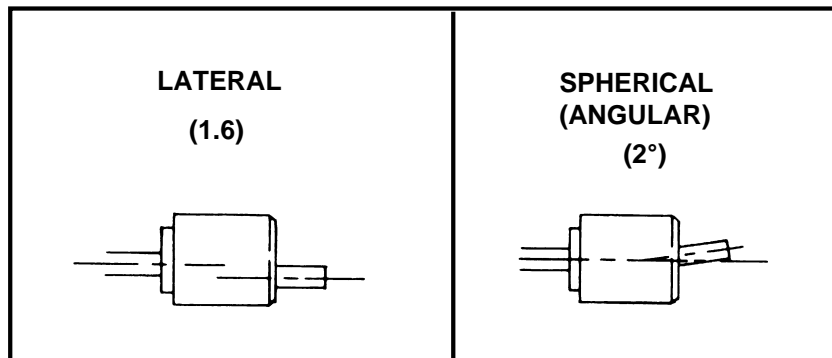

All dimensions are in mm

Metric Self-Aligning Couplers

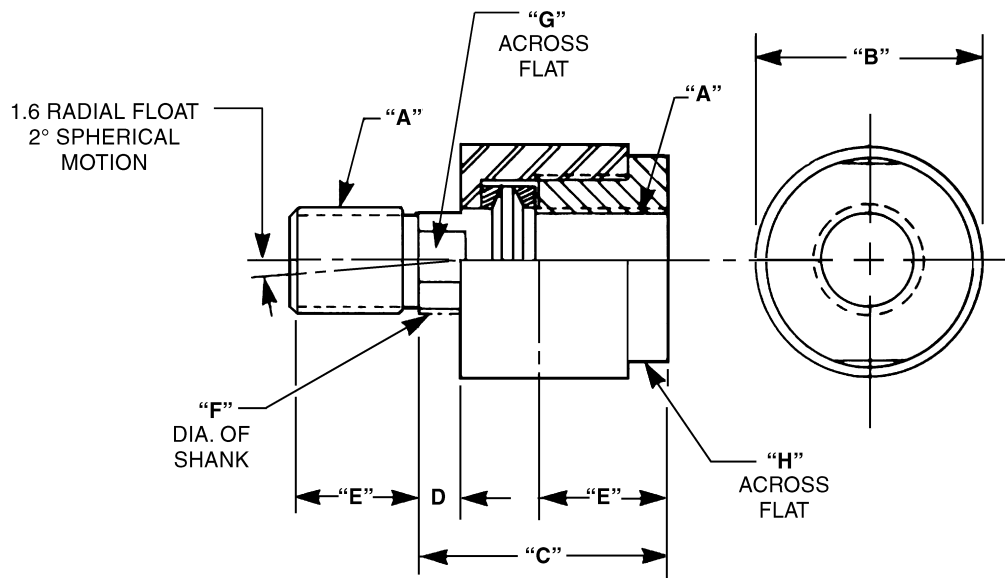

Metric

CAD FILE NAME	PART NUMBER	A	B	C	D	E	F	G	H
AC080M	EAC-080M	M8 x 1	31.7	50.8	12.7	20	15.8	14.2	29
AC100M	EAC-100M	M10 x 1.25	31.7	50.8	12.7	20	15.8	14.2	29
AC120M	EAC-120M	M12 x 1.25	31.7	50.8	12.7	20	15.8	14.2	29
AC140M	EAC-140M	M14 x 1.5	31.7	50.8	12.7	20	15.8	14.2	29
AC160M	EAC-160M	M16 x 1.5	44.4	59.4	8	28.5	24.5	22.2	38.1
AC180M	EAC-180M	M18 x 1.5	44.4	59.4	8	28.5	24.5	22.2	38.1
AC200M	EAC-200M	M20 x 1.5	44.4	59.4	8	28.5	24.5	22.2	38.1
AC220M	EAC-220M	M22 x 1.5	44.4	59.4	8	28.5	24.5	22.2	38.1
AC240M	EAC-240M	M24 x 2	63.5	75	11	41	35	32	57
AC260M	EAC-260M	M26 x 1.5	63.5	75	11	41	35	32	57
AC270M	EAC-270M	M27 x 2	63.5	75	11	41	35	32	57
AC300M	EAC-300M	M30 x 2	63.5	75	11	41	35	32	57
AC330M	EAC-330M	M33 x 2	63.5	75	11	41	35	32	57
AC360M	EAC-360M	M36 x 2	82.5	111	20.6	57	44.5	38	76
AC420M	EAC-420M	M42 x 2	82.5	111	20.6	57	44.5	38	76