

Metric Air Powered Rota-Shaft Clamps with Cylinders Linear/Rotary

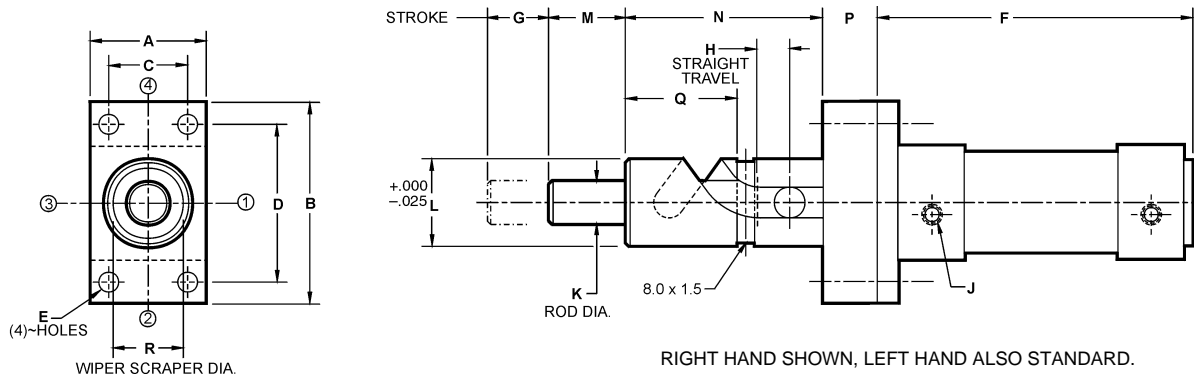

CAD FILE NAME	PART NUMBER	CYLINDER BORE	ROTATION	DIMENSIONS																
				A	B	C	D	E	F	G	H	J	K	L	M	N	P	Q	R	
EM20401	EPM-20-40-A-10-(R/L)	40	10°	52.0	92.0	36.0	72.0	9.0	144.0	25.0	15.0	(1/4) BSP/G	20.0	39.975	35.0	90.0	25.0	51.0	32.0	
EM20402	EPM-20-40-A-30-(R/L)	40	30°	52.0	92.0	36.0	72.0	9.0	149.0	30.0	15.0	(1/4) BSP/G	20.0	39.975	35.0	90.0	25.0	51.0	32.0	
EM20403	EPM-20-40-A-60-(R/L)	40	60°	52.0	92.0	36.0	72.0	9.0	154.0	35.0	15.0	(1/4) BSP/G	20.0	39.975	35.0	90.0	25.0	51.0	32.0	
EM20404	EPM-20-40-A-90-(R/L)	40	90°	52.0	92.0	36.0	72.0	9.0	159.0	40.0	15.0	(1/4) BSP/G	20.0	39.975	35.0	90.0	25.0	51.0	32.0	
EM20405	EPM-20-40-A-125-(R/L)	40	125°	52.0	92.0	36.0	72.0	9.0	164.0	45.0	15.0	(1/4) BSP/G	20.0	39.975	35.0	90.0	25.0	51.0	32.0	
EM20406	EPM-20-40-A-150-(R/L)	40	150°	52.0	92.0	36.0	72.0	9.0	169.0	50.0	15.0	(1/4) BSP/G	20.0	39.975	35.0	90.0	25.0	51.0	32.0	
EM20407	EPM-20-40-A-180-(R/L)	40	180°	52.0	92.0	36.0	72.0	9.0	174.0	55.0	15.0	(1/4) BSP/G	20.0	39.975	35.0	90.0	25.0	51.0	32.0	
EM25501	EPM-25-50-A-10-(R/L)	50	10°	63.5	113.0	45.0	90.0	9.0	142.0	20.0	10.0	1/4 BSP/G	25.0	44.975	35.0	100.0	30.0	56.0	37.0	
EM25502	EPM-25-50-A-45-(R/L)	50	45°	63.5	113.0	45.0	90.0	9.0	152.0	30.0	10.0	1/4 BSP/G	25.0	44.975	35.0	100.0	30.0	56.0	37.0	
EM25503	EPM-25-50-A-90-(R/L)	50	90°	63.5	113.0	45.0	90.0	9.0	162.0	40.0	10.0	1/4 BSP/G	25.0	44.975	35.0	100.0	30.0	56.0	37.0	
EM25504	EPM-25-50-A-135-(R/L)	50	135°	63.5	113.0	45.0	90.0	9.0	172.0	50.0	10.0	1/4 BSP/G	25.0	44.975	35.0	100.0	30.0	56.0	37.0	
EM25505	EPM-25-50-A-180-(R/L)	50	180°	63.5	113.0	45.0	90.0	9.0	182.0	60.0	10.0	1/4 BSP/G	25.0	44.975	35.0	100.0	30.0	56.0	37.0	
EM25631	EPM-25-63-A-10-(R/L)	63	10°	76.0	129.0	50.0	100.0	9.0	157.0	20.0	10.0	3/8 BSP/G	25.0	44.975	35.0	100.0	30.0	56.0	37.0	
EM25632	EPM-25-63-A-45-(R/L)	63	45°	76.0	129.0	50.0	100.0	9.0	167.0	30.0	10.0	3/8 BSP/G	25.0	44.975	35.0	100.0	30.0	56.0	37.0	
EM25633	EPM-25-63-A-90-(R/L)	63	90°	76.0	129.0	50.0	100.0	9.0	177.0	40.0	10.0	3/8 BSP/G	25.0	44.975	35.0	100.0	30.0	56.0	37.0	
EM25634	EPM-25-63-A-135-(R/L)	63	135°	76.0	129.0	50.0	100.0	9.0	187.0	50.0	10.0	3/8 BSP/G	25.0	44.975	35.0	100.0	30.0	56.0	37.0	
EM25635	EPM-25-63-A-180-(R/L)	63	180°	76.0	129.0	50.0	100.0	9.0	197.0	60.0	10.0	3/8 BSP/G	25.0	44.975	35.0	100.0	30.0	56.0	37.0	
EM30801	EPM-30-80-A-15-(R/L)	80	15°	95.5	153.0	63.0	126.0	12.0	173.0	25.0	15.0	3/8 BSP/G	30.0	49.975	50.0	135.0	35.0	71.0	42.0	
EM30802	EPM-30-80-A-45-(R/L)	80	45°	95.5	153.0	63.0	126.0	12.0	183.0	35.0	15.0	3/8 BSP/G	30.0	49.975	50.0	135.0	35.0	71.0	42.0	
EM30803	EPM-30-80-A-90-(R/L)	80	90°	95.5	153.0	63.0	126.0	12.0	198.0	50.0	15.0	3/8 BSP/G	30.0	49.975	50.0	135.0	35.0	71.0	42.0	
EM30804	EPM-30-80-A-135-(R/L)	80	135°	95.5	153.0	63.0	126.0	12.0	213.0	65.0	15.0	3/8 BSP/G	30.0	49.975	50.0	135.0	35.0	71.0	42.0	
EM30805	EPM-30-80-A-180-(R/L)	80	180°	95.5	153.0	63.0	126.0	12.0	228.0	80.0	15.0	3/8 BSP/G	30.0	49.975	50.0	135.0	35.0	71.0	42.0	
EM301001	EPM-30-100-A-15-(R/L)	100	15°	114.5	186.0	75.0	150.0	14.0	183.0	25.0	15.0	1/2 BSP/G	30.0	49.975	50.0	135.0	35.0	71.0	42.0	
EM301002	EPM-30-100-A-45-(R/L)	100	45°	114.5	186.0	75.0	150.0	14.0	193.0	35.0	15.0	1/2 BSP/G	30.0	49.975	50.0	135.0	35.0	71.0	42.0	
EM301003	EPM-30-100-A-90-(R/L)	100	90°	114.5	186.0	75.0	150.0	14.0	208.0	50.0	15.0	1/2 BSP/G	30.0	49.975	50.0	135.0	35.0	71.0	42.0	
EM301004	EPM-30-100-A-135-(R/L)	100	135°	114.5	186.0	75.0	150.0	14.0	223.0	65.0	15.0	1/2 BSP/G	30.0	49.975	50.0	135.0	35.0	71.0	42.0	
EM301005	EPM-30-100-A-180-(R/L)	100	180°	114.5	186.0	75.0	150.0	14.0	238.0	80.0	15.0	1/2 BSP/G	30.0	49.975	50.0	135.0	35.0	71.0	42.0	

ISO 6431 AIR CYLINDER, MAXIMUM RECOMMENDED OPERATING PRESSURE = 10 bar
 MAX VELOCITY = 300 cm/min

Metric Hydraulic Powered Rota-Shaft Clamps with Cylinders Linear/Rotary

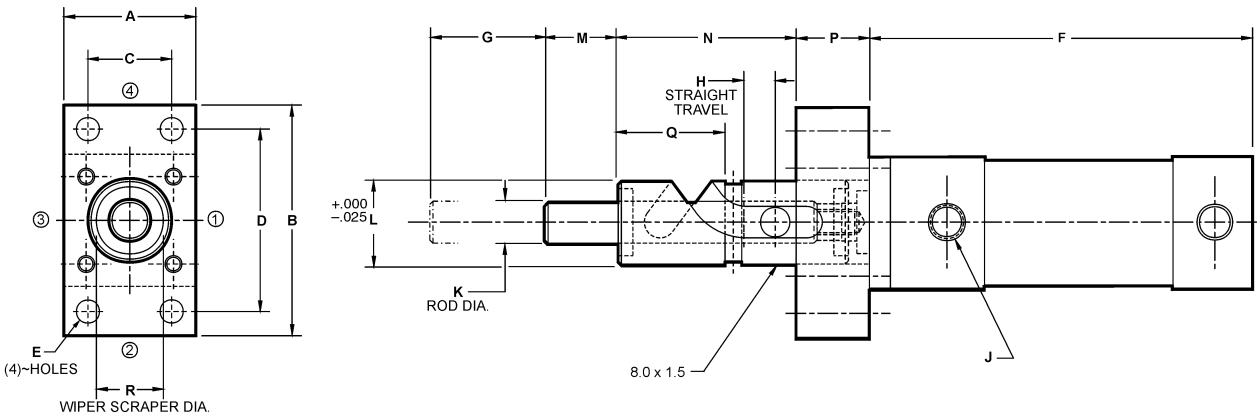

RIGHT HAND SHOWN, LEFT HAND ALSO STANDARD.

CAD FILE NAME	PART NUMBER	CYLINDER BORE	ROTATION	DIMENSIONS																
				A	B	C	D	E	F	G	H	J	K	L	M	N	P	Q	R	
EMH20401	EPM-20-40-H-10-(R/L)	40	10°	63.0	110.0	41.0	87.0	11.0	153.0	25.0	15.0	(3/8) BSP/G	20.0	39.975	35.0	85.0	35.0	51.0	32.0	
EMH20402	EPM-20-40-H-30-(R/L)	40	30°	63.0	110.0	41.0	87.0	11.0	158.0	30.0	15.0	(3/8) BSP/G	20.0	39.975	35.0	85.0	35.0	51.0	32.0	
EMH20403	EPM-20-40-H-60-(R/L)	40	60°	63.0	110.0	41.0	87.0	11.0	163.0	35.0	15.0	(3/8) BSP/G	20.0	39.975	35.0	85.0	35.0	51.0	32.0	
EMH20404	EPM-20-40-H-90-(R/L)	40	90°	63.0	110.0	41.0	87.0	11.0	168.0	40.0	15.0	(3/8) BSP/G	20.0	39.975	35.0	85.0	35.0	51.0	32.0	
EMH20405	EPM-20-40-H-125-(R/L)	40	125°	63.0	110.0	41.0	87.0	11.0	173.0	45.0	15.0	(3/8) BSP/G	20.0	39.975	35.0	85.0	35.0	51.0	32.0	
EMH20406	EPM-20-40-H-150-(R/L)	40	150°	63.0	110.0	41.0	87.0	11.0	178.0	50.0	15.0	(3/8) BSP/G	20.0	39.975	35.0	85.0	35.0	51.0	32.0	
EMH20407	EPM-20-40-H-180-(R/L)	40	180°	63.0	110.0	41.0	87.0	11.0	183.0	55.0	15.0	(3/8) BSP/G	20.0	39.975	35.0	85.0	35.0	51.0	32.0	
EMH25501	EPM-25-50-H-10-(R/L)	50	10°	75.0	130.0	52.0	105.0	13.0	159.0	25.0	15.0	(1/2) BSP/G	25.0	44.975	35.0	95.0	35.0	56.0	37.0	
EMH25502	EPM-25-50-H-45-(R/L)	50	45°	75.0	130.0	52.0	105.0	13.0	169.0	35.0	15.0	(1/2) BSP/G	25.0	44.975	35.0	95.0	35.0	56.0	37.0	
EMH25503	EPM-25-50-H-90-(R/L)	50	90°	75.0	130.0	52.0	105.0	13.0	179.0	45.0	15.0	(1/2) BSP/G	25.0	44.975	35.0	95.0	35.0	56.0	37.0	
EMH25504	EPM-25-50-H-135-(R/L)	50	135°	75.0	130.0	52.0	105.0	13.0	189.0	55.0	15.0	(1/2) BSP/G	25.0	44.975	35.0	95.0	35.0	56.0	37.0	
EMH25505	EPM-25-50-H-180-(R/L)	50	180°	75.0	130.0	52.0	105.0	13.0	199.0	65.0	15.0	(1/2) BSP/G	25.0	44.975	35.0	95.0	35.0	56.0	37.0	
EMH30631	EPM-30-63-H-15-(R/L)	63	15°	90.0	150.0	65.0	125.0	13.0	161.0	25.0	15.0	(1/2) BSP/G	30.0	49.975	50.0	137.0	35.0	71.0	42.0	
EMH30632	EPM-30-63-H-45-(R/L)	63	45°	90.0	150.0	65.0	125.0	13.0	171.0	35.0	15.0	(1/2) BSP/G	30.0	49.975	50.0	137.0	35.0	71.0	42.0	
EMH30633	EPM-30-63-H-90-(R/L)	63	90°	90.0	150.0	65.0	125.0	13.0	186.0	50.0	15.0	(1/2) BSP/G	30.0	49.975	50.0	137.0	35.0	71.0	42.0	
EMH30634	EPM-30-63-H-120-(R/L)	63	120°	90.0	150.0	65.0	125.0	13.0	196.0	60.0	15.0	(1/2) BSP/G	30.0	49.975	50.0	137.0	35.0	71.0	42.0	
EMH30635	EPM-30-63-H-135-(R/L)	63	135°	90.0	150.0	65.0	125.0	13.0	206.0	70.0	15.0	(1/2) BSP/G	30.0	49.975	50.0	137.0	35.0	71.0	42.0	

ISO 6020/2 HYDRAULIC CYLINDER, MAXIMUM RECOMMENDED OPERATING PRESSURE = 210 bar
 MAX VELOCITY = 300 cm/min

Metric Air Powered Rota-Shaft Clamps with Cylinders Rotary/Linear

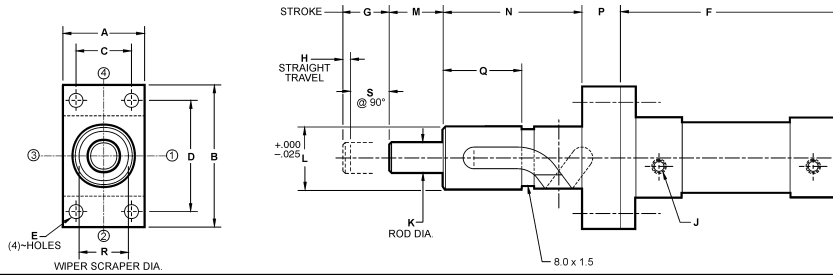

CAD FILE NAME	PART NUMBER	CYLINDER BORE	ROTATION	DIMENSIONS																
				A	B	C	D	E	F	G	H	J	K	L	M	N	P	Q	R	S
EM02401	EPM-02-40-A-90-(R/L)-30	40	90°	52.0	92.0	36.0	72.0	9.0	149.0	30.0	5.0	(1/4) BSP/G	20.0	39.975	35.0	90.0	25.0	51.0	32.0	25.0
EM02402	EPM-02-40-A-90-(R/L)-35	40	90°	52.0	92.0	36.0	72.0	9.0	154.0	35.0	10.0	(1/4) BSP/G	20.0	39.975	35.0	90.0	25.0	51.0	32.0	25.0
EM02403	EPM-02-40-A-90-(R/L)-40	40	90°	52.0	92.0	36.0	72.0	9.0	159.0	40.0	15.0	(1/4) BSP/G	20.0	39.975	35.0	90.0	25.0	51.0	32.0	25.0
EM02404	EPM-02-40-A-90-(R/L)-45	40	90°	52.0	92.0	36.0	72.0	9.0	164.0	45.0	20.0	(1/4) BSP/G	20.0	39.975	35.0	90.0	25.0	51.0	32.0	25.0
EM02405	EPM-02-40-A-90-(R/L)-50	40	90°	52.0	92.0	36.0	72.0	9.0	169.0	50.0	25.0	(1/4) BSP/G	20.0	39.975	35.0	90.0	25.0	51.0	32.0	25.0
EM02406	EPM-02-40-A-90-(R/L)-55	40	90°	52.0	92.0	36.0	72.0	9.0	174.0	55.0	30.0	(1/4) BSP/G	20.0	39.975	35.0	90.0	25.0	51.0	32.0	25.0
EM52501	EPM-52-50-A-90-(R/L)-35	50	90°	63.5	113.0	45.0	90.0	9.0	157.0	35.0	5.0	(1/4) BSP/G	25.0	44.975	35.0	100.0	30.0	56.0	37.0	30.0
EM52502	EPM-52-50-A-90-(R/L)-40	50	90°	63.5	113.0	45.0	90.0	9.0	162.0	40.0	10.0	(1/4) BSP/G	25.0	44.975	35.0	100.0	30.0	56.0	37.0	30.0
EM52503	EPM-52-50-A-90-(R/L)-45	50	90°	63.5	113.0	45.0	90.0	9.0	167.0	45.0	15.0	(1/4) BSP/G	25.0	44.975	35.0	100.0	30.0	56.0	37.0	30.0
EM52504	EPM-52-50-A-90-(R/L)-50	50	90°	63.5	113.0	45.0	90.0	9.0	172.0	50.0	20.0	(1/4) BSP/G	25.0	44.975	35.0	100.0	30.0	56.0	37.0	30.0
EM52505	EPM-52-50-A-90-(R/L)-55	50	90°	63.5	113.0	45.0	90.0	9.0	177.0	55.0	25.0	(1/4) BSP/G	25.0	44.975	35.0	100.0	30.0	56.0	37.0	30.0
EM52506	EPM-52-50-A-90-(R/L)-60	50	90°	63.5	113.0	45.0	90.0	9.0	182.0	60.0	30.0	(1/4) BSP/G	25.0	44.975	35.0	100.0	30.0	56.0	37.0	30.0
EM52631	EPM-52-63-A-90-(R/L)-35	63	90°	76.0	129.0	50.0	100.0	9.0	172.0	35.0	5.0	(3/8) BSP/G	25.0	44.975	35.0	100.0	30.0	56.0	37.0	30.0
EM52632	EPM-52-63-A-90-(R/L)-40	63	90°	76.0	129.0	50.0	100.0	9.0	177.0	40.0	10.0	(3/8) BSP/G	25.0	44.975	35.0	100.0	30.0	56.0	37.0	30.0
EM52633	EPM-52-63-A-90-(R/L)-45	63	90°	76.0	129.0	50.0	100.0	9.0	182.0	45.0	15.0	(3/8) BSP/G	25.0	44.975	35.0	100.0	30.0	56.0	37.0	30.0
EM52634	EPM-52-63-A-90-(R/L)-50	63	90°	76.0	129.0	50.0	100.0	9.0	187.0	50.0	20.0	(3/8) BSP/G	25.0	44.975	35.0	100.0	30.0	56.0	37.0	30.0
EM52635	EPM-52-63-A-90-(R/L)-55	63	90°	76.0	129.0	50.0	100.0	9.0	192.0	55.0	25.0	(3/8) BSP/G	25.0	44.975	35.0	100.0	30.0	56.0	37.0	30.0
EM52636	EPM-52-63-A-90-(R/L)-60	63	90°	76.0	129.0	50.0	100.0	9.0	197.0	60.0	30.0	(3/8) BSP/G	25.0	44.975	35.0	100.0	30.0	56.0	37.0	30.0
EM03801	EPM-03-80-A-90-(R/L)-40	80	90°	95.5	153.0	63.0	126.0	12.0	188.0	40.0	5.0	3/8 BSP/G	30.0	49.975	50.0	135.0	35.0	71.0	42.0	35.0
EM03802	EPM-03-80-A-90-(R/L)-45	80	90°	95.5	153.0	63.0	126.0	12.0	193.0	45.0	10.0	3/8 BSP/G	30.0	49.975	50.0	135.0	35.0	71.0	42.0	35.0
EM03803	EPM-03-80-A-90-(R/L)-50	80	90°	95.5	153.0	63.0	126.0	12.0	198.0	50.0	15.0	3/8 BSP/G	30.0	49.975	50.0	135.0	35.0	71.0	42.0	35.0
EM03804	EPM-03-80-A-90-(R/L)-55	80	90°	95.5	153.0	63.0	126.0	12.0	203.0	55.0	20.0	3/8 BSP/G	30.0	49.975	50.0	135.0	35.0	71.0	42.0	35.0
EM03805	EPM-03-80-A-90-(R/L)-60	80	80°	95.5	153.0	63.0	126.0	12.0	208.0	60.0	25.0	3/8 BSP/G	30.0	49.975	50.0	135.0	35.0	71.0	42.0	35.0
EM03806	EPM-03-80-A-90-(R/L)-65	80	90°	95.5	153.0	63.0	126.0	12.0	213.0	65.0	30.0	3/8 BSP/G	30.0	49.975	50.0	135.0	35.0	71.0	42.0	35.0
EM03807	EPM-03-80-A-90-(R/L)-70	80	90°	95.5	153.0	63.0	126.0	12.0	218.0	70.0	35.0	3/8 BSP/G	30.0	49.975	50.0	135.0	35.0	71.0	42.0	35.0
EM03808	EPM-03-80-A-90-(R/L)-75	80	90°	95.5	153.0	63.0	126.0	12.0	223.0	75.0	40.0	3/8 BSP/G	30.0	49.975	50.0	135.0	35.0	71.0	42.0	35.0
EM031001	EPM-03-100-A-90-(R/L)-40	100	90°	114.5	186.0	75.0	150.0	14.0	198.0	40.0	5.0	1/2 BSP/G	30.0	49.975	50.0	135.0	35.0	71.0	42.0	35.0
EM031002	EPM-03-100-A-90-(R/L)-45	100	90°	114.5	186.0	75.0	150.0	14.0	203.0	45.0	10.0	1/2 BSP/G	30.0	49.975	50.0	135.0	35.0	71.0	42.0	35.0
EM031003	EPM-03-100-A-90-(R/L)-50	100	90°	114.5	186.0	75.0	150.0	14.0	208.0	50.0	15.0	1/2 BSP/G	30.0	49.975	50.0	135.0	35.0	71.0	42.0	35.0
EM031004	EPM-03-100-A-90-(R/L)-55	100	90°	114.5	186.0	75.0	150.0	14.0	213.0	55.0	20.0	1/2 BSP/G	30.0	49.975	50.0	135.0	35.0	71.0	42.0	35.0
EM031005	EPM-03-100-A-90-(R/L)-60	100	90°	114.5	186.0	75.0	150.0	14.0	218.0	60.0	25.0	1/2 BSP/G	30.0	49.975	50.0	135.0	35.0	71.0	42.0	35.0
EM031006	EPM-03-100-A-90-(R/L)-65	100	90°	114.5	186.0	75.0	150.0	14.0	223.0	65.0	30.0	1/2 BSP/G	30.0	49.975	50.0	135.0	35.0	71.0	42.0	35.0
EM031007	EPM-03-100-A-90-(R/L)-70	100	90°	114.5	186.0	75.0	150.0	14.0	228.0	70.0	35.0	1/2 BSP/G	30.0	49.975	50.0	135.0	35.0	71.0	42.0	35.0
EM031008	EPM-03-100-A-90-(R/L)-75	100	90°	114.5	186.0	75.0	150.0	14.0	233.0	75.0	40.0	1/2 BSP/G	30.0	49.975	50.0	135.0	35.0	71.0	42.0	35.0

Metric Hydraulic Powered Rota-Shaft Clamps with Cylinders Rotary/Linear

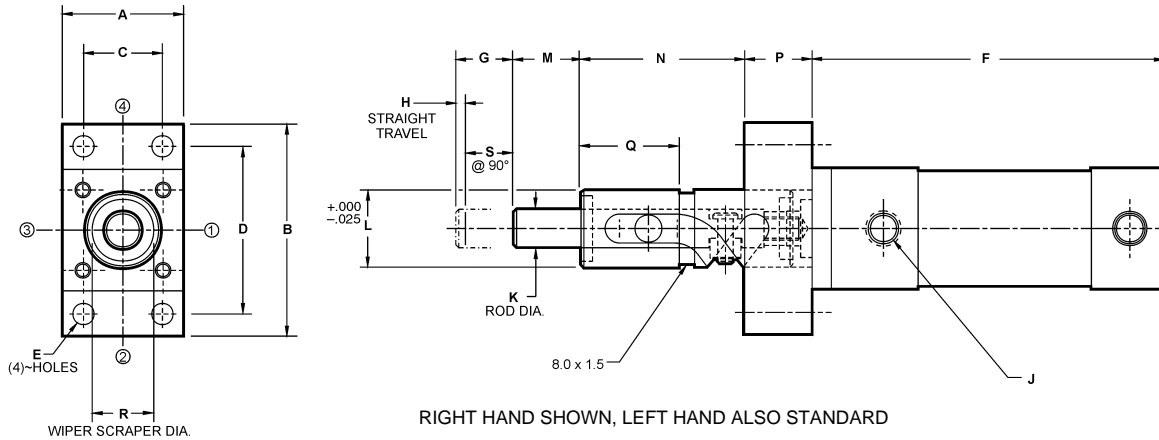

CAD FILE NAME	PART NUMBER	CYLINDER BORE	ROTATION	DIMENSIONS																
				A	B	C	D	E	F	G	H	J	K	L	M	N	P	Q	R	S
EMH02401	EPM-02-40-H-90-(R/L)-30	40	90°	63.0	110.0	41.0	87.0	11.0	158.0	30.0	5.0	(3/8) BSP/G	20.0	39.975	35.0	85.0	35.0	51.0	32.0	25.0
EMH02402	EPM-02-40-H-90-(R/L)-30	40	90°	63.0	110.0	41.0	87.0	11.0	163.0	35.0	10.0	(3/8) BSP/G	20.0	39.975	35.0	85.0	35.0	51.0	32.0	25.0
EMH02403	EPM-02-40-H-90-(R/L)-30	40	90°	63.0	110.0	41.0	87.0	11.0	168.0	40.0	15.0	(3/8) BSP/G	20.0	39.975	35.0	85.0	35.0	51.0	32.0	25.0
EMH02404	EPM-02-40-H-90-(R/L)-30	40	90°	63.0	110.0	41.0	87.0	11.0	173.0	45.0	20.0	(3/8) BSP/G	20.0	39.975	35.0	85.0	35.0	51.0	32.0	25.0
EMH02405	EPM-02-40-H-90-(R/L)-30	40	90°	63.0	110.0	41.0	87.0	11.0	178.0	50.0	25.0	(3/8) BSP/G	20.0	39.975	35.0	85.0	35.0	51.0	32.0	25.0
EMH02406	EPM-02-40-H-90-(R/L)-30	40	90°	63.0	110.0	41.0	87.0	11.0	183.0	55.0	30.0	(3/8) BSP/G	20.0	39.975	35.0	85.0	35.0	51.0	32.0	25.0
EMH52501	EPM-52-50-H-90-(R/L)-35	50	90°	75.0	130.0	52.0	105.0	13.0	169.0	35.0	5.0	(1/2) BSP/G	25.0	44.975	40.0	90.0	35.0	56.0	37.0	30.0
EMH52502	EPM-52-50-H-90-(R/L)-40	50	90°	75.0	130.0	52.0	105.0	13.0	174.0	40.0	10.0	(1/2) BSP/G	25.0	44.975	40.0	90.0	35.0	56.0	37.0	30.0
EMH52503	EPM-52-50-H-90-(R/L)-45	50	90°	75.0	130.0	52.0	105.0	13.0	179.0	45.0	15.0	(1/2) BSP/G	25.0	44.975	40.0	90.0	35.0	56.0	37.0	30.0
EMH52504	EPM-52-50-H-90-(R/L)-50	50	90°	75.0	130.0	52.0	105.0	13.0	184.0	50.0	20.0	(1/2) BSP/G	25.0	44.975	40.0	90.0	35.0	56.0	37.0	30.0
EMH52505	EPM-52-50-H-90-(R/L)-55	50	90°	75.0	130.0	52.0	105.0	13.0	189.0	55.0	25.0	(1/2) BSP/G	25.0	44.975	40.0	90.0	35.0	56.0	37.0	30.0
EMH52506	EPM-52-50-H-90-(R/L)-60	50	90°	75.0	130.0	52.0	105.0	13.0	194.0	60.0	30.0	(1/2) BSP/G	25.0	44.975	40.0	90.0	35.0	56.0	37.0	30.0
EMH03631	EPM-03-63-H-90-(R/L)-40	63	90°	90.0	150.0	65.0	125.0	13.0	176.0	40.0	5.0	(1/2) BSP/G	30.0	49.975	50.0	137.0	35.0	71.0	42.0	35.0
EMH03632	EPM-03-63-H-90-(R/L)-45	63	90°	90.0	150.0	65.0	125.0	13.0	181.0	45.0	10.0	(1/2) BSP/G	30.0	49.975	50.0	137.0	35.0	71.0	42.0	35.0
EMH03633	EPM-03-63-H-90-(R/L)-50	63	90°	90.0	150.0	65.0	125.0	13.0	186.0	50.0	15.0	(1/2) BSP/G	30.0	49.975	50.0	137.0	35.0	71.0	42.0	35.0
EMH03634	EPM-03-63-H-90-(R/L)-55	63	90°	90.0	150.0	65.0	125.0	13.0	191.0	55.0	20.0	(1/2) BSP/G	30.0	49.975	50.0	137.0	35.0	71.0	42.0	35.0
EMH03635	EPM-03-63-H-90-(R/L)-60	63	90°	90.0	150.0	65.0	125.0	13.0	196.0	60.0	25.0	(1/2) BSP/G	30.0	49.975	50.0	137.0	35.0	71.0	42.0	35.0
EMH03636	EPM-03-63-H-90-(R/L)-65	63	90°	90.0	150.0	65.0	125.0	13.0	201.0	65.0	30.0	(1/2) BSP/G	30.0	49.975	50.0	137.0	35.0	71.0	42.0	35.0

ISO 6020/2 HYDRAULOC CYLINDER, MAXIMUM RECOMMENDED OPERATING PRESSURE = 210 bar
 MAX VELOCITY = 300 cm/min